

HDP 70 High Pressure Pump Series

Design criteria

Hammelmann high pressure pumps are built to operate at the continuous maximum duty stated in the performance parameters. Just compare the crankshaft speed, average plunger speed, plunger diameter and power rating.

High pressure pump

Weight: approx. 215 kg

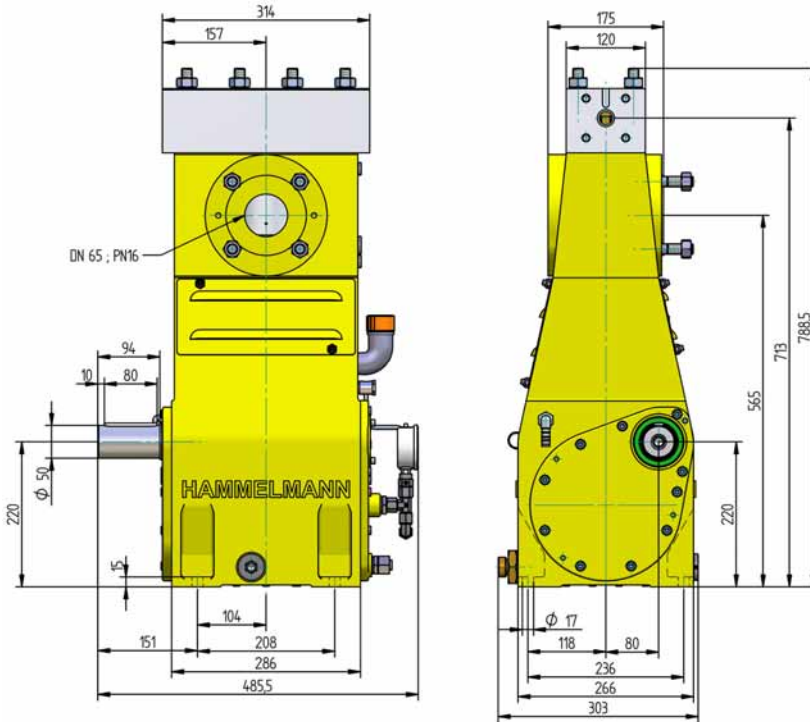

Energy efficient →



Features

- Power ratings up to 70 kW
- Vertical 3 cylinder design
- Wide variety of complementary ancillaries

Quality and reliability

- Stainless steel pump head free of alternating stress
- Bellows form hermetic seal between the suction chamber and crank section
- Choice of application specific seal assemblies
- Solid ceramic or tungsten carbide plungers
- Choice of bronze (standard) or stainless steel suction chamber
- Crank section calculation by 'Finite element method' ensures long working life under continuous load
- Integral speed reduction gear
- Pressurised oil lubrication system with oil cooler/filter

Stationary unit with electric motor

Length: 1502 mm
 Width: 720 mm
 Height: 1105 mm
 Weight: approx. 1150 kg at 75 kW

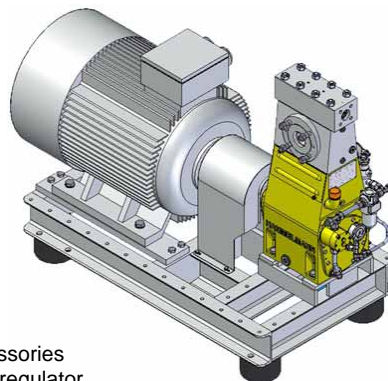

Main dimensions without accessories such as suction line, pressure regulator etc. All shown as right side drive. Detailed dimensional drawings and weights available on request.

HDP 70 series, technical data

Performance parameters (Standard design)

Note: Actual flow rates for water as pumped medium (volumetric efficiency has already been taken into account).

HDP	Q [l/min]	Required power rating [kW]					D	r.p.m.		
		30	37	45	55	70		n 1	n 2	
		Operating pressure [bar]								
74	7,2 / 7,2* 9,2 / 8,7* 11 / 10,4*	2000*	2450*	3000*	3000*	3000*	12	1500	625	
		1650	2050*	2500*	3000*			1500/1800	750	
		1400	1700	2100*	2550*	3000*			1800/2150	900
74	11,9 / 11,3* 14,3 / 13,5* 17,2 / 16,2*	1250	1550	1900	2350*	2400*	15	1500	625	
		1050	1300	1600	1950	2400*			1500/1800	750
		890	1100	1300	1600	2050*			1800/2150	900
74	17 19,5 23	930	1150	1400	1700	1750	17,5	1500	625	
		780	970	1150	1400	1750			1500/1800	750
		650	810	980	1200	1500			1800/2150	900

*Ultra high pressure

73	21	710	880	1050	1300	20	1500	625
	26	600	740	900	1100		1500/1800	750

72	26	600	740	900	1100	1130	22	1500	625	
	32	500	610	750	910	1130			1500/1800	750
	32	500	620	750	920	950		24	1500	625
	38	420	520	630	780	950				1500/1800
	38	430	530	640	780	810		26	1500	625
	45	350	440	530	650	810				1500/1800
	50	320	390	480	590			30	1500	625
	59	260	330	400	490	600				1500/1800
	69	230	290	350	430			35	1500	625
	81	190	240	290	360	440				1500/1800
	91	180	220	270	330			40	1500	625
	107	150	180	220	270	340				1500/1800
	115	140	170	210	260			45	1500	625
	135	110	140	170	210	270				1500/1800
	142	110	130	170	210			50	1500	625
	167	90	110	140	170	210				1500/1800
172	90	110	140	170		55	1500	625		
201	70	90	110	140	180			1500/1800	750	
246**	60	70	100	120	150		1800/2150	900		

**For intermittent operation only

HDP	Seal ***	Sealing system
74	Dynamic	Tungsten carbide plunger & bushing
	Packing	Special ceramic plunger **** / packing
73	Dynamic	Ceramic plunger / bronze bushing
	Packing	Ceramic plunger / packing
72	Dynamic	Ceramic plunger / bronze bushing
	Packing	Ceramik plunger / packing

*** The dynamic high pressure sealing extends the advantages of the labyrinth design with further increased efficiency.

**** Special ceramic plungers up to max. 2600 bar.

D = Piston/Plunger dia. [mm]
n1 = Motor/Engine r.p.m.
n2 = Crankshaft r.p.m.

Conversion table

Rating 1 kW = 1.34 HP
Op. pressure 1 bar = 14.5 psi
Flow rate 1 l = 0.264 US gallon
1 l = 0.22 Imp. gallon

- Rod force: 43 kN
- Stroke: 40 mm
- Mean piston speed at n₂
625 r.p.m. = 0,84 m/sec
750 r.p.m. = 1,00 m/sec
900 r.p.m. = 1,20 m/sec

Typical high pressure pump units



- Stationary unit with electric motor



- Trolley



- Road going or stationary trailer units with sound damping cover
- 10 or 20 foot sound damped container versions

Energy efficient →

Hammelmann plunger pumps convert 93 to 98 % of the shaft power to hydraulic energy.

Hammelmann Maschinenfabrik GmbH

Postfach 3309 • D-59282 Oelde Telefon (0 25 22) 76-0
Zum Sundern 13-21 • Germany Telefax (0 25 22) 76-444
eMail: mail@hammelmann.de • Internet: www.hammelmann.com

HAMMELMANN®